

Floor Varieties



Quality Design with Durability in Mind

Arctic believes the best walk-in cooler is built from the ground up and starts with a top-rated floor. Arctic cooler floors are designed and manufactured with the highest quality and testing standards in the industry. The floor of your Arctic cooler is meticulously tested and constructed for reliability and specified for the use of the cooler. Whether a standard or heavy-duty floor, Arctic is continuously engineering new and state-of-the-art methods to ensure customer satisfaction, safety, and certification. As we speak, our R & D team is working on the next generation of walk-in floor enhancements, while our robotic floor testing machine is running 24/7 to set new industry standards in quality and accuracy.

Arctic Floor Common Finish Options



Economy

600lbs
lbs per sq. foot



Standard

1200lbs
lbs per sq. foot



Heavy Duty

1500lbs
lbs per sq. foot



Pallet Jack

2600lbs
lbs per sq. foot

Arctic Floor Finish Options

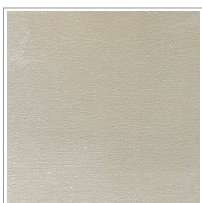

0.063
Smooth
Aluminum

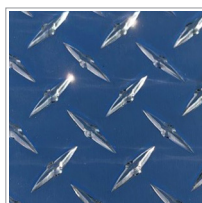

0.100
Aluminum
Diamond
Treatplate

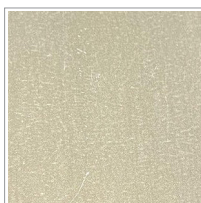

16 Ga
Bonderized
Galvanized



16 Ga
Smooth
Galvanized

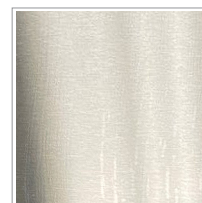

16 Ga
Stainless
Steel

Economy Floors

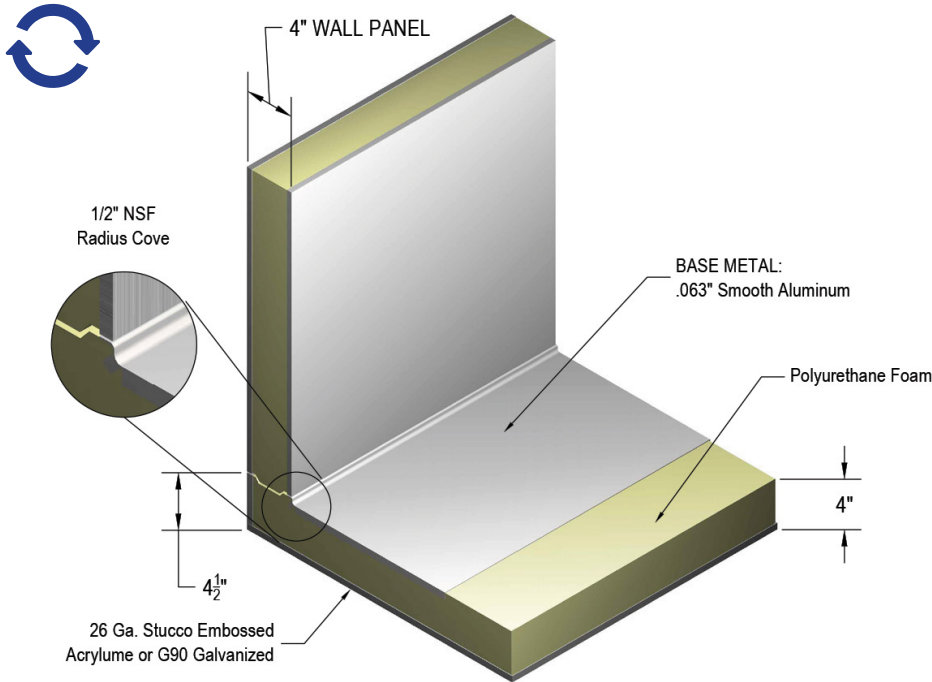

Features:

- With a static load rating of 600 lbs/ft² is the preferred option for the client whose needs are best suited with a smaller walk-in at a great price point
- Economy Floors come standard with our .063" Smooth Aluminum floor finish
- Suitable for all foot traffic. Not suitable for rolling racks, hand trucks or carts

Standard Floors

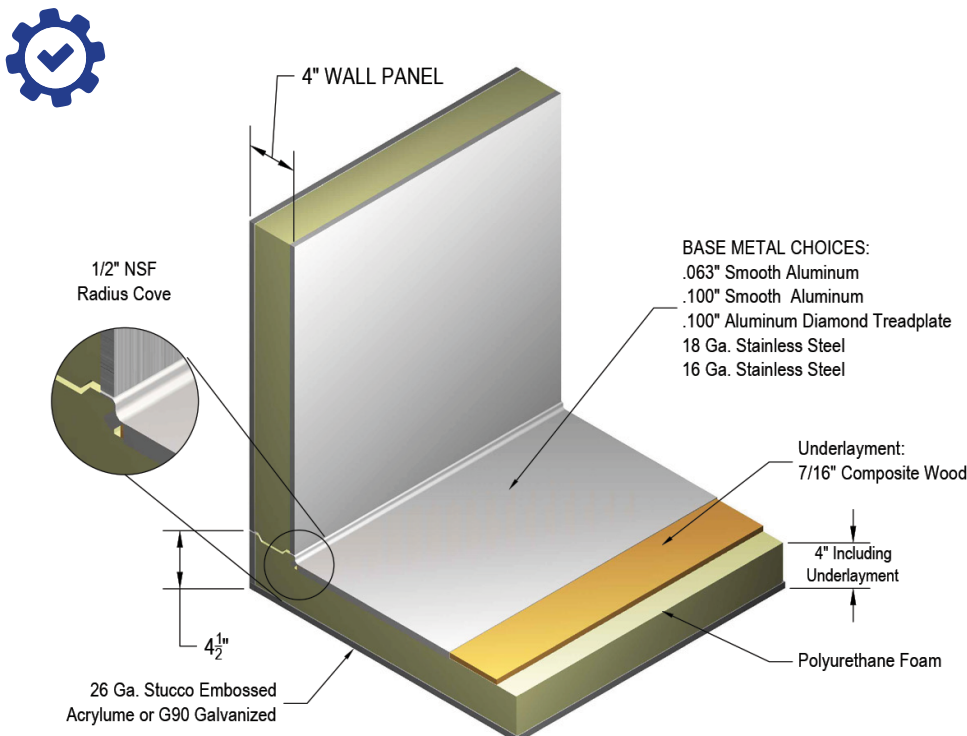

Features:

- With a static load rating of 1,200 lbs/ft², this floor has OSB wood underlayment for added strength and comes standard on our Signature Series walk-ins
- 5 different base metal choices, our Standard Floors allow us to find the best fit for our clients, while staying within their budget
- Suitable for light hand trucks and light carts. Not suitable for heavy duty use

Heavy Duty Floors

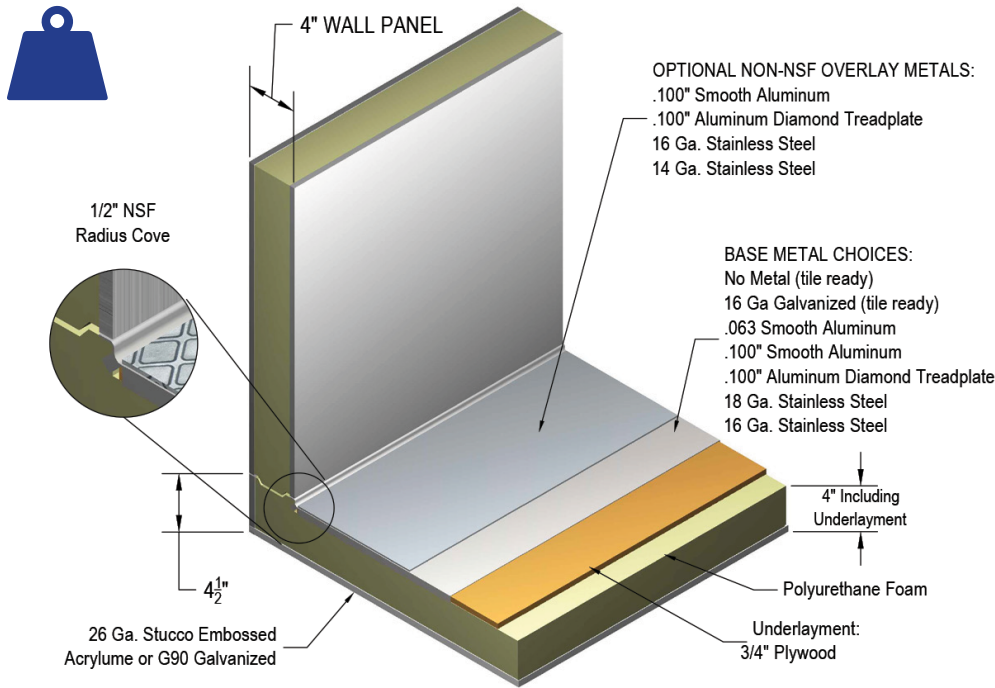

Features:

- With a static load rating of 1,500 lbs/ft², this floor has 3/4" plywood underlayment for superior strength
- 7 different base metal choices and 4 optional Non-NSF overlay metal choices. Overlays ship loose - installation required.
- Suitable for heavy traffic from hand trucks, rolling racks and loading carts. Not suitable for pallet jack use

Pallet Jack Floors

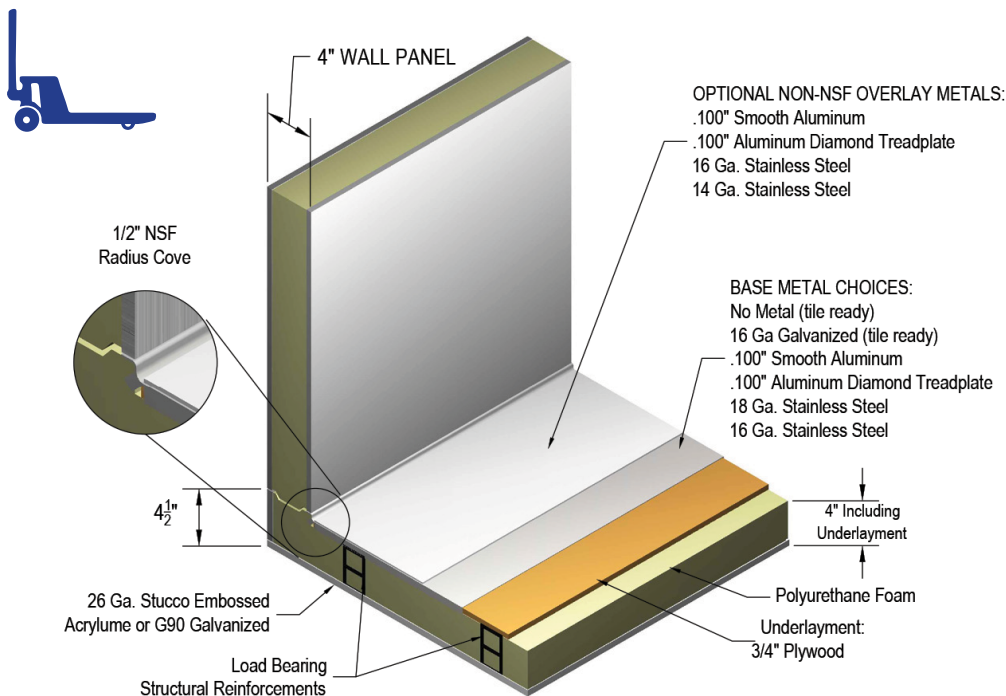

Features:

- With the highest static of 2,600 lbs/ft², this floor has 3/4" plywood underlayment and comes standard with foamed in place load bearing structural reinforcements
- 6 base metal choices and 4 optional Non-NSF overlay metal choices for every taste and application. Overlays ship loose - installation required.
- Suitable for keg carts, rolling racks and pallet jack use

Floor Testing R&D

Floor panel ratings have long been required throughout the walk-in industry to ensure customers have the right floor for their project. Arctic is putting in the research and development resources to guarantee the floors we engineer are designed, tested and manufactured based on science and quality as well. The latest test results on floor ratings and usage expectations are coming soon from your team at Arctic.

